

# Power Factor Correction and Harmonics Effect to an Industrial load

S.K.Abeygunawardane<sup>1</sup>, K.I.R.Prasanna<sup>2</sup>, A.Arulampalam<sup>3</sup> and J.B.Ekanayake<sup>4</sup>

*Department of Electrical & Electronic Engineering, University of Peradeniya*

## Introduction

In the proposed long term development plan, the Government of Sri Lanka has targeted to establish many new industries. To achieve this, electricity generation should be increased. Since we can not expect major power additions to the national system until proposed power projects are completed, effective energy management is important. For higher utilization of power, power factor has to be maintained at closer to unity at every usage point of electricity [1].

At low power factor, transmission lines carry both active power and reactive power and it increases line current and line losses. On the other hand CEB charges for high reactive power consumption through kVA demand. Therefore power factor correction is beneficial to the supplier in terms of line loss and also to the consumer in terms of bill payment. However, the harmonic loads make sever effects to the power factor correction capacitor banks [2], [3], [4]. It has been noted that several industries are suffering from burning capacitors.

This paper presents the power factor correction method for inductive loads using capacitor banks, and harmonic loads' effect on the power factor correction capacitors. All effects are resonated with the simulation and experimental results. To control harmonics in industries passive filters, active filters or combined systems can be used [5].

This paper proposes the Sri Lankan industries to use harmonic filters in order to protect capacitor banks from harmonics.

## Methodology

An inductive load supplied from three phase was modeled in EMTDC/PSCAD computer simulation package. This has also been made in laboratory scale experimental setup. Power factor correction was carried out using a capacitor bank. A three phase rectifier load was used to produce the harmonics and its effects were checked using oscilloscope. The laboratory scale experimental setup is shown

in Figure 1. The corresponding simplified electrical circuit diagram is shown in Figure 2.

As shown in Figure 2, a three phase induction motor and a delta connected three phase inductor bank were connected to a three phase supply. This is to represent industrial loads, mostly which are inductive in nature. Then current and voltage waveforms were observed using the oscilloscope. Assume the lagging power factor of the system is  $\cos\phi_1$ .

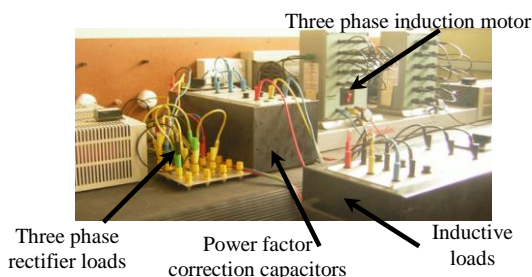

Figure 1. Photograph of the experimental setup

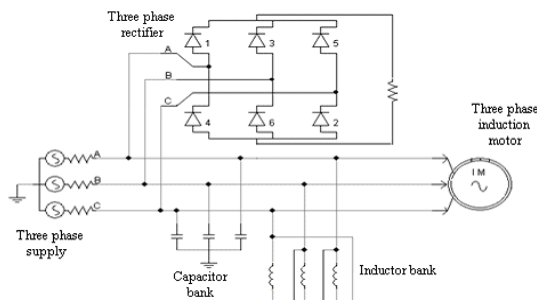

Figure 2. Electrical circuit diagram of the studied system

Theoretically, a capacitor of  $Q$  kVAr can be used to compensate same inductive power to produce  $\cos\phi = 1$ . But it is not a common practice as it is not much cost effective and may result in overcompensation due to load changes. Therefore it compensates to get a specified value;  $\cos\phi_2$ , to which the power factor should be corrected.

Next, a three phase capacitor bank was connected in parallel to loads to implement power factor correction, and waveforms were observed.

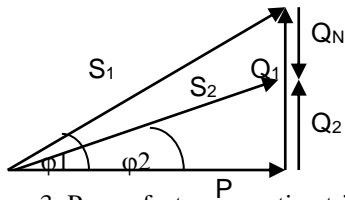

Figure 3: Power factor correction triangle

- P = Active power
- $S_1, Q_1$  = Uncompensated apparent power and reactive power
- $S_2, Q_2$  = Apparent power and reactive power after power factor correction
- $Q_N$  = Reactive power compensated by the capacitor

A three phase rectifier which generates harmonics was connected in parallel to loads. The effect of the presence of harmonics in the system to the capacitor bank was also observed. Finally, a simulation study was carried out for the above circuit and experimental results were compared with the simulation results.

### Results

The experimental and simulation results are shown in Figures 4, 5, 6 and 7. Experimental results are shown in left side while the simulation results are on the right side.

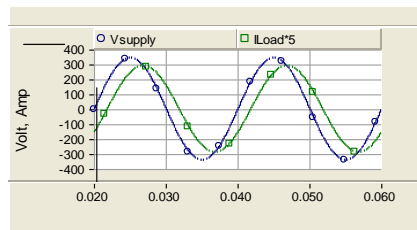
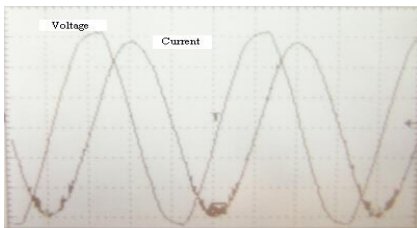

Figure 4. Waveform of the supply voltage and load current

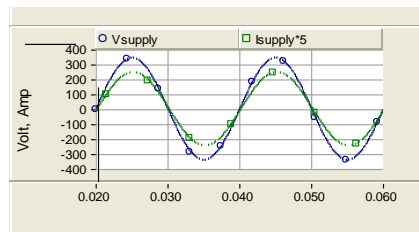
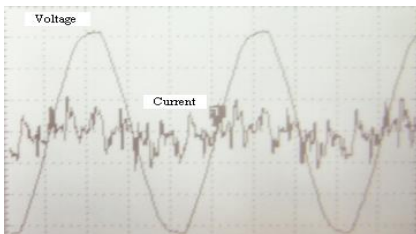

Figure 5. Waveform of the supply voltage and supply current

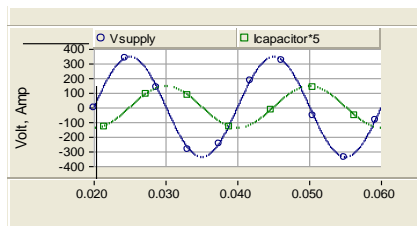
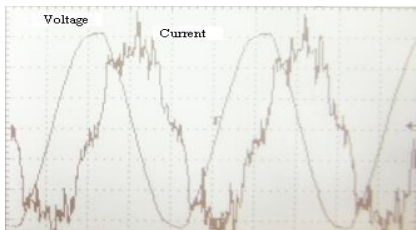

Figure 6. Waveform of the supply voltage and capacitor current

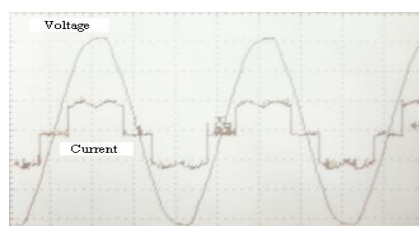
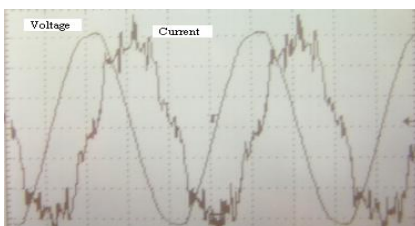

Figure 7. Waveforms of the capacitor current and harmonic load current with supply voltage

## Discussion

Power factor correction capacitor bank can be used for power factor improvement in industries, which are normally having highly inductive loads. When the power factor correction capacitor bank is connected to the system with inductive loads total current drawn from the supply is reduced as shown in Figures 4 and 5. This confirms that the supplier current is reduced and thus the maximum kVA demand also reduced.

However, the capacitor bank introduces more harmonics to the system. This can be observed from the load and supply current waveforms shown in Figures 4 and 5. This is mainly because of the already existing harmonics in the supply voltage. This can be further confirm when compare the capacitor current in simulation and experimental waveforms shown in Figure 5. Here the supply voltage had the harmonics while simulation the harmonics was not there.

When a rectifier harmonic load is added to the system, it injects more harmonic current to the grid. In this case according to the characteristics of the power factor correction capacitors, they show low impedance to the harmonic current. Therefore the capacitor current waveform in Figure 7 is increased. However, in this experimental set up a small harmonic load was used and also the supply voltage already consists harmonics due to neighborhood harmonic loads. Therefore significant increment in the harmonic current could not be seen when harmonic load was added. As a result it can be concluded that the harmonic current increased in the power factor correction capacitors when harmonic loads are added to the grid in neighborhood areas.

Recently many industries already placed several variable speed drives for energy saving purpose. Most of these are heavy harmonic loads. Therefore the harmonic current drawn in to the power factor correction capacitors will also be increased. An industry must consider about its already installed power factor correction capacitor, because this will heat the capacitor and finally the capacitor will get damage.

## Conclusion

This study clearly explains the benefits of the putting the power factor correction to the industries and the CEB suppliers. Also it proves that the harmonic current will increase with harmonic load additions such as variable speed drives. Therefore it has given clear explanation

to the capacitor heating in industries when they installed more harmonic loads after installing the power factor capacitors. Therefore proper monitoring of the harmonic content is important for proper operation of the power factor correction capacitor. To control harmonics in industries, a harmonic filter can be used. In the future we plan to study the design of filters and practically implement a filter for harmonic control.

## References

- Wang D.H., Cheng K.W.E, "General discussion on energy saving", First International Conference on Power Electronics Systems and Applications, November 2004, pages 298 – 303.
- C. J. Gajanayake, G. Ramtharan, G. K. Samaraweera, A. Atputharajah, J. B. Ekanayake, "A survey of harmonic current at several industries in Sri Lanka", Journal of the National Science Foundation, Sri Lanka, Vol. 33, No. 3, September 2005, Pages 205 – 217.
- Shwedhi M.H., Sultan M.R., "Power factor correction capacitors; essentials and cautions", Power Engineering Society Summer Meeting, 2000, IEEE Volume 3, Issue : 2000, Pages:1317 – 1322.
- Wagner V.E., Balda J.C., Griffith D.C., McEachern A., Barnes T.M., Hartmann D.P., Phileggi D.J., Emmanuel A.E., Horton W.F., Reid W.E., Ferraro R.J., Jewell W.T, "Effects of harmonics on equipment", Power Delivery, IEEE Transactions, Volume: 8, Issue: 2, Apr 1993, Pages: 672-680.
- Fang-Zheng Peng, Hirofumi Akagi, Akira Nabae, "A new approach to harmonic compensation in power system- A combined system of series active and shunt passive filters", Electrical Engineering in Japan, Vol. 110, No. 5, 1990, Pages:88-98.

## Acknowledgment

The authors are acknowledging Mr. M.G.H Ranatunga, Mr. R.S. Abeythunga, Mr. T.C. Dissanayake, Miss. L.Karunanayake for their support in arranging the set up.

---