

# Over Speed Recognition and Vehicle Theft Managing System Using Raspberry Pi

Ilayaraja R 1, Gayathri L 2, Gomathy S 3, and Haripriya B 4.

*1 Assistant professor, Sri sairam Engineering College,*

*2,3,4 UG Scholars, Sri sairam Engineering College*

*1 ilayaraja.ice@sairam.edu.in*

*2 srilekshmigayathri@gmail.com*

*3 gomathy492@gmail.com*

*4 haripriyabphv@gmail.com*

**Abstract - With the emergence of new technology and innovations, people are looking for smarter ways to protect/monitor their properties remotely. In accordance to that, at present GPS based tracking system is frequently used in vehicle tracking, children/pet tracking, aircraft tracking, any personal belongings tracking, fleet management and so on. This paper introduces a Smart Anti-Theft Vehicle System based on Internet of Things (IoT) for monitoring the movement of any equipped vehicle from anywhere in real time. At the implementation of this system, Global Positioning System (GPS) and Microcontrollers are used to enable users for monitoring their vehicles in a convenient manner. This system provides the access to check the movement and control (emergency stop by closing the fuel line) vehicles remotely by using mobile application. The hardware prototype of the proposed system and the user application for monitoring and controlling vehicles are presented in this paper.**

**Keywords - Internet of things; Raspberry pi; Wi-Fi; GPS;**

## I. INTRODUCTION

With the increase in applications of various embedded technology, vehicle security system design and tracking are improving. Many new techniques, like image processing, communication via biometric recognition and so many interesting techniques have been implemented in vehicle security systems. Simultaneously, the number accident of vehicles and vehicle theft still remains high. We believe this system can create a better impact in controlling accidents by monitoring over speed. Normally vehicle security system depends on many sensors which are not affordable by everyone. It is almost impossible to track a stolen or missing vehicle without the help of sensors. So our paper aims to overcome the existing problem of vehicle theft by monitoring and blocking the over speed vehicles without using sensors. The main objective is to measure the signals and to interface them with HDMI monitor which are then transmitted to the webpage through Raspberry pi to the traffic constable and the vehicle owner's Mobile using IoT. The Vehicle engine immobilizer using GSM already exists. But it has drawbacks like, high roaming costs, tampering of calls and need for an external module for interfacing Microcontroller etc. By implementing IoT we can overcome these drawbacks. Internet of thing (IoT) is an advanced technology which helps devices to stay connected among them. Each and every smart device can communicate with each other with the help of Network.

Internet is used everywhere from small mobiles till high end data servers. There are billions of devices which can be accessed or connected using IoT as shown in Fig-1. They can be paired together and exchange data across, or remote login to make life simpler. This paper presents a combined effort to bring the Automotives and Android System together to serve the Purpose of vehicle tracking. A smart phone has over-ruled almost many devices together and now we can use the same for the purpose of centre locking the vehicle and tracing if missed. The proposed design provides information about vehicle number, identity, speed, and position. This information are collected by the raspberry pi and send to the control station where it stores the information in database.

## II. LITERATURE REVIEW

Some of the literature reviews are as follows 1“*A Wireless Home Safety Gas Leakage Detection System*” by LuayFriwan, KhaldonLweesy, AyaBani-Salma, Nour Mani. This module checks if a change in concentration of gases has exceeded a certain pre-determined threshold. 2“*An IoT framework for intelligent vehicle monitoring system*” by Rahul B. Pendor. The uniquely detecting capability of vehicle using RFID sensor network makes it a better choice. 3 “*Real time muti-channel gas leak monitoring system using CPLD chip,*” Sensors and Actuators B, Vol. 77, pp. 186- 189, 2001 by W.Chung, and D. Lee. 4 “*An IoT based scholar bus monitoring system*” by Ricardo Quintero, Computer Science Department, Technological Institute of Culiacan. Sinaloa, Mexico. This paper presents the development of an IoT based scholar bus monitoring system that through localization and speed sensors will allow many stakeholders such as parents to trace the bus. 5 “*Internet of things (iot) based real time gas leakage monitoring and controlling*” by JayavardhanaGubbi, RajkumarBuyya, Slaven Marusic, Marimuthu Palaniswamia, Internet of Things (IoT): A Vision, Architectural Elements, and Future Directions. This platform developed a prototype of an automatic embedded system that constantly monitors the gas leak status with the help of the electronic sensors. The outline of this paper is that, the stolen vehicle's data will be collected from the owner, and is given to the police. Then the stolen vehicle's data will be retrieved from the database and transmitted to receiver (Raspberry pi). The receiver processes the data which results in blocking of the engine. Also, to block over speeding vehicles, the speed data is given from the transceiver and transmitted to the web page. This information is used to block the over speeding vehicle.

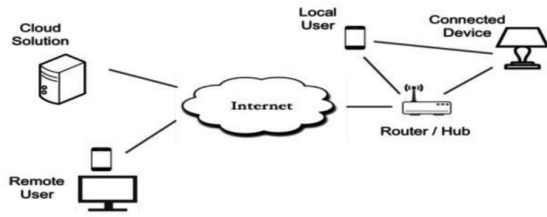

Fig. 1: Block diagram representation of interconnection of devices using IoT

### III. COMPONENT SPECIFICATIONS

#### 1. Raspberry pi Controller

We use raspberry pi 3 in the proposed design as it has the added advantage of built in Wi-Fi. It is an ATM card size computer. The power is about 1.5 watts to 6.7 watts. The storage capacity is MicroSDHC slot. It has a memory size of 1GB LPDDR2 RAM at 900 MHz It has a built-in SDRAM of 256MB. Whereas model B has 51MB. As in every controller the CPU is the brain of the raspberry pi board. The responsibility of the CPU is to carry out the instructions through logical and arithmetical operations. The CPU memory is about 1.2 GHz 64/32 bit QUADCORE ARMC. The controller makes use of ARM11 series processor, which has joined hands with Samsung galaxy phone. The GPU in raspberry pi board is a specialized chip which is designed for the purpose of speeding up the image calculation operations. The controller is intended with a Broadcom video core IV. It also gives assistance to OpenGL. The controller's Ethernet port is the main access for interfacing it with additional devices. This port is used to plug the domicile router to get in touch with the internet. The LCD or HD TV monitors can be attached to the controller by using an HDMI main cable and with an adaptor.

#### 2. Solid State Relay

A solid state relay is a switching device that toggles between on and off when an external voltage of small amount is applied across the control terminals. In this paper, it is used as a switch to identify over speed in case of theft actions. The various specifications of solid state relay are as follows  
 Control Voltage: 24-380V AC  
 Input Voltage : 3-32V DC  
 Trigger Current : 7.5mA/12V

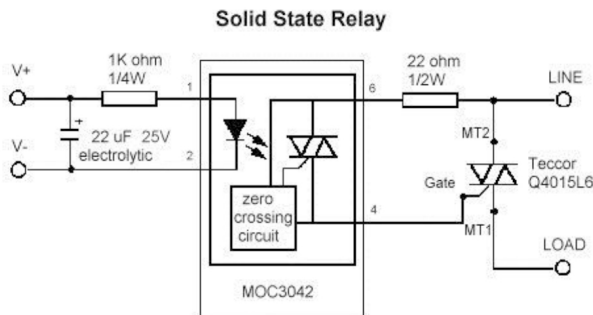

Fig. 2: Solid State Relay

Varying the voltage across the solid state relay, results in controlling the fuel flow to the engine. Finally immobilization of the engine takes place when maximum speed is reached, or when the theft action is detected.

#### 3. DC Servo Motor

We use DC servo motor as an indicator of Vehicle Engine in the proposed design. It is a rotary actuator that admits detailed control of angular position, acceleration and velocity. By connecting the varying outputs of DC servomotor to the solid-state relay, the supply to the relay is varied. This act is to indicate that the varying speed of the vehicle disturbs the supply to the solid state relay and makes it work in accordance to the corresponding inputs. We use servomotor as it has specialized characteristics such as high-response and high-precision positioning.

#### 4. Optocoupler

Optocouplers or opto-isolators are used as a safe passage between the high power circuit and the low power control circuit. It merely converts signals between high voltage pitot devices and low voltage solid-state logic circuits. They are primarily used to safeguard the electronic components from damaging by separating them from voltage fluctuations. Thus optocoupler also acts as a point of interaction between two circuits.

#### 5. Step down Transformer

In a step-down transformer the secondary side has smaller amount of turns than the primary side. The induced voltage across the secondary coil is less than the applied voltage across the primary coil thus the voltage is stepped-down. Transformers are mostly used to convert the 220 volts electricity to the 110 volts required in most common equipment. Copper windings are much more efficient than aluminium and many other metal windings.

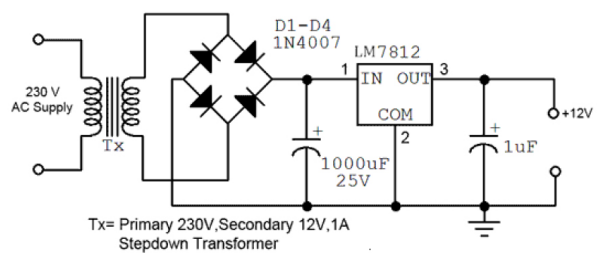

Fig. 3: Step Down Transformer

#### 6. Wi-Fi Modem

A wireless fidelity modem act as a bypass to the telephone system and connects directly to a wireless network, through which we can directly approach the Internet connectivity supplied by an Internet service provider. It has a range of 32 meters (105 ft). IoT is anticipated to provide enhanced communication among devices, systems, and services that goes farther more than machine to machine (M2M) communications and is also extended to a variety of protocols, domains.

### IV. WORKING DESCRIPTION

The proposed design is placed in the vehicle during the registration of the vehicle. In case of theft, the owner sends the vehicle information to the respective authorities. After receiving that information the data are fed to the webpage for further actions. Initially the raspberry pi board in the corresponding vehicle is accessed. As the result a buzzer warning is given to the thief. In case of ignorance the fuel to the engine is blocked. However sudden blockage of fuel supply may cause road accidents. So the fuel is blocked step by step through the solenoid valve.

### V. WORKING OF FUNCTIONAL BLOCKS

#### 1. Power Supply Block

Building our own DC power from an AC source of 110 volt AC or 220 volt AC is essential for this proposed design. The most commonly used power supply by domestic devices is of the range 3 volt DC to 30 volt DC. Classically the most common types are 5 volt, 9 volt, 12 volt, 15 volt and 18 volt DC supply. Amid the encroachment of machinery, lots of devices uses 1.8 volt DC now-a-days. SMPS is fetching attraction in recent times as the need for miniaturization increases to gain space constrains.

We call for a step down transformer to bow out the AC voltage from the line voltage of 110 volt AC or 220 volt AC prior to using it as a supply to the diode bridges.

The proposed methodology calls for a LM338 adaptable 3 terminal regulator to deliver a current of about 5A above a variable output voltage of 2 volt to 25 volt DC. In addition to that we require a LM318 adjustable 3 terminal regulator to provide a current of about 1.5A with customized 12 volts DC Voltage. A simple DC regulated structure using 7805 voltage regulator is employed to obtain a variable DC voltage range from 5V to 15V. Variable 5 volts to 20 volts DC Power supply is build with the help of National Semiconductor LM2941 low dropout voltage regulator. Constructing a 12V DC Switch Mode Power supply from AC source of 85 to 265 volts AC is essential.

A USB charger circuit is built to ensure cost sensitive application. It uses the MCP73853/MCP73855 linear charge management controllers. They are exclusively designed for USB applications and adhere to all the USB specifications governing the USB power bus.

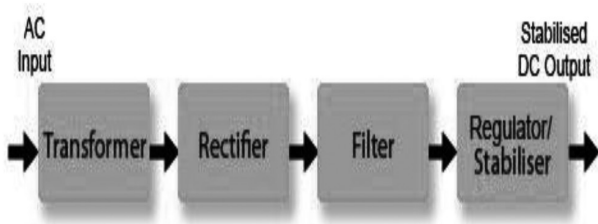

Fig. 4: Block Diagram of Power Supply Block

#### 2. Fuel Block

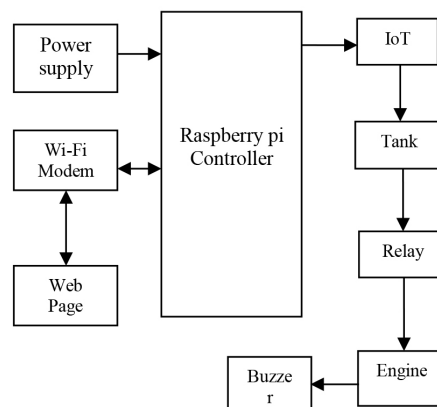

Fig. 5: Block Diagram of Fuel Block

A webpage is created for data base retrieving purpose and is connected through Wi-Fi to the Raspberry pi controller. An external power supply is given to the controller as shown in the fig. Through IoT the controller is connected with the Tank and then the tank is connected to the relay which later acts as a switch for blocking fuel. A buzzer is connected with the fuel block so that an advanced alert can be given to the drivers of other vehicle surrounding the theft vehicle. This avoids accidents due to sudden immobilizing of the theft or over speeding vehicles.

#### 3. Over Speed Control Block

If the output of the solid state relay is found to be 12 V then the information like vehicle number and location are given to the web page through the transceiver. This information helps the police to trace the Over Speeding vehicle and thereby block it. The flow chart for the over speed control process is given as follows.

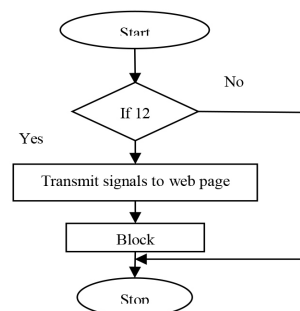

Fig. 7: Flow Chart of Speed Control and Blocking System

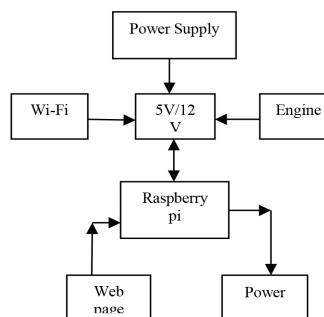

Fig. 6: Block Diagram of over Speed Control Block

## VI. PROGRAM

We prefer using Linux because of the dominance of Android on smart phones, Linux has the largest installed base of all general-purpose operating systems. Linux is also the leading operating system on servers and other big iron systems such as mainframe computers, and is used on 99.6% of the TOP500 supercomputers. It is used by around 2.3% of desktop computers. Linux also runs on embedded systems – devices whose operating system is typically built into the firmware and is highly tailored to the system. This includes TiVo and similar DVR devices, network routers, facility automation controls, televisions, video game consoles and smart watches.

### Programming code

```

import com.pi4j.wiringpi.Gpio;

import com.pi4j.wiringpi.GpioUtil;

public class WiringPiGpioExample {

    // Simple sequencer data

    // Triplets of LED, On/Off and delay

    private static final int data[] = {

        0, 1, 1, 1, 1, 0, 0, 0, 2, 1, 1, 1, 0, 0, 3, 1, 1, 2, 0

, 0, 4, 1, 1, 3, 0, 0, 5, 1, 1, 4,

        0, 0, 6, 1, 1, 5, 0, 0, 7, 1, 1, 6, 0, 1, 7, 0, 1,

        0, 0,

0, 0,

        1,

// Extra delay

        // Back again

        7, 1, 1, 6, 1, 1, 7, 0, 0, 5, 1, 1, 6, 0, 0, 4, 1, 1, 5, 0, 0,

3, 1, 1, 4, 0, 0, 2,

        1, 3, 0, 0, 1, 1, 1, 2, 0, 0, 0, 1, 1, 1, 0, 1, 0, 0, 1,

        0, 0, 1, // Extra delay

        9, 9, 9, // End marker

    }; }

    for (pin = 0; pin < 7; ++pin) {

        }

        = 0;

    for (;;) {

        l = data[dataPtr++]; // LED

        s = data[dataPtr++]; // State

        d = data[dataPtr++]; // Duration (10ths)

        if ((l + s + d) == 27) {

            dataPtr = 0;

            continue;

        }

        Gpio.digitalWrite(l, s);

        if (Gpio.digitalRead(7) == 1) // Pressed as our s

            witch shorts to ground

        Gpio.delay(d * 10); // Faster!

```

```

else
    Gpio.delay(d * 100);
}
}
}
    
```

**VII. CONCLUSION**

- In existing model GSM model is used. In which we cannot block the vehicle but we can track the place of the vehicle.
- By using Raspberry pi with IoT we can block the vehicle.
- This model enables to control from remote location.
- The engine cannot be started again without owners reset.
- Reduces the bike theft to larger extent over speed can also be avoided.



**Fig. 8: Hardware Setup**

**VIII. RESULT**

This paper focuses on developing a prototype which acts as a vehicle engine immobilizer for anti-theft, over speeding and prevention of accident in drunk and drive cases. Emerging technology IoT is being implemented in this proposed design instead of GSM. Thus we have many advantages like improved speed in information sharing, reliability and redundancy. Our proposal will give its fullest outcome in smart cities where we have sufficient Wi-Fi facilities. However it can also be used in remote areas. Our future development will be implementing finger print tracing techniques in this proposed design so that we can identify the thief with ease.

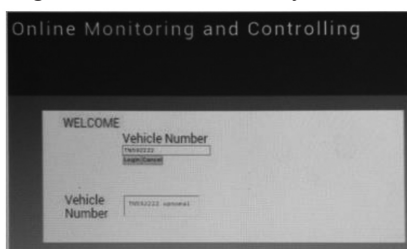

**Fig. 9: Image of the Web Page**

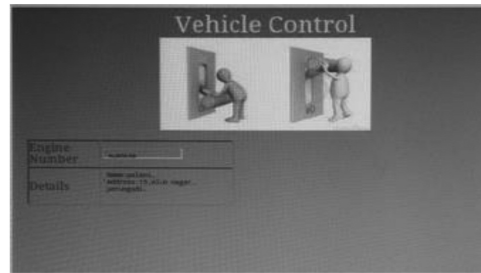

**Fig.10: Details Retrieved**

**ACKNOWLEDGMENT**

We thank our founder chairman late. Shri MJF .Ln.Leo Muthu , for his visionary in establishing this great institution. We express our deep sense of gratitude to our beloved and respected CEO Mr. J. Sai Prakash Leo Muthu for the excellent infrastructural facilities with state of the art laboratories, sufficient resources and his sincere endeavor in imparting education to us in this premier institution. We express our gratitude to our principal Dr.C.V.Jayakumar for having given us spontaneous and whole hearted encouragement for completing this paper. We wish to express our sincere thanks and gratitude to our Head of the Department Mrs.T.Mangayarkarasi for the moral support, encouragement and advice she has given us in completing our paper. Finally, we thank all the faculty members and technicians of the Department of Instrumentation and Control Engineering who contributed directly and indirectly for the successful completion of this paper.

**References**

1. "An IoT framework for intelligent vehicle monitoring system" Rahul B.Pendor 2016 International Conference on Communication and Signal Processing (ICCSPP)
2. "An IoT based scholar bus monitoring system" Ricardo Quintero 2015 IEEE First International Smart Cities Conference (ISC2) Technological Institute of Culiacan Sinaloa, Mexico.
3. "Raspberry Pi Based Vehicle Tracking And Security System For Real Time Applications" D.Santhoshi Rani et al, International Journal of Computer Science and Mobile Computing, Vol.5 Issue.7, July- 2016, pg. 387-393.
4. "IoT-based anti-theft and remote controlling system for automobiles" IHemant Kuruva, 2Girish Shiva Prasanna Raju S. International Journal of Science, Engineering and Technology Research (IJSETR) Volume 5, Issue 12, December 2016.
5. "Smart Vehicle Monitoring System Using Raspberry Pi" 1Tabassum Jalal Khan, 2M.R.Bhadange, 3Pooja Sanjay Pagar, 4Prof. Vinaya Salve Spvryan's International Journal of Engineering Sciences & Technology (SEST) ISSN : 2394-0905.
6. "IoT for Smart Car using Raspberry PI" Leelavathi T C1, Dr. Shivaleelavathi B G2, Shubha B3n IoT framework, International Research Journal of Engineering and Technology (IRJET) e-ISSN: 2395 -0056 Volume: 03 Issue: 06 June-2016 www.irjet.net p-ISSN: 2395-0072 © 2016, IRJET Impact Factor value: 4.45 ISO 9001:2008 Certified Journal Page 1376 .
7. "Study of Theft Detection and Tracking using Raspberry pi and PIR Sensor" Rahane Madhuri, Pathak Mayuri, Wadekar Ashabai, More Rupali, Malkar Ankita International Journal of Latest Trends in Engineering and Technology (IJLTET).
8. "Real time vehicle monitoring and tracking system based on embedded Linux board and android application" Prashant A. Shinde ; Y. B. Mane ; Pandurang H. Tarange, Published in: 2015 International Conference on Circuits, Power and Computing Technologies [ICCPCT-2015].
9. Beginning of Linux programming by Neil Matthew, Richard Stones

10. Sadhana Godbole, Shivani Deshpande, Neha Barve, Sakshi Galim –NBSSOE, “Review on Theft Prevention System using Raspberry Pi and PIR Sensor”, International Journal of Computer Applications (0975 – 8887) Volume 155 – No 11.
11. Ashwini Patil, Shobha Mondhe, Tejashri Ahire, Gayatri Sonar, “AUTO-THEFT DETECTION USING RASPBERRY PI AND ANDROID APP” International Journal of Research in Engineering Application & Management (IJREAM) ISSN: 2494 - 9150 Vol-02, Issue 07, Oct 2016.
12. Safa. H, Sakthi Priyanka .N, Vikkashini Gokul Priya .S, Vishnupriya .S, Boobalan .T, “IOT based Theft Preemption and Security System”, International Journal of Innovative Research in Science, Engineering, and Technology(An ISO 3297: 2007 Certified Organization)Vol. 5, Issue 3, March 2016